

PRODUCT BROCHURE

# Simply Smart Low Voltage System Motor Control Center with Motor Control and Protection Unit M10x



- A reliable, available, simple, safe and powerful low voltage motor control center solution

---

**ABB low voltage MCC with M10x is the intelligent motor control center solution integrating protection, control, monitoring and communication through single M10x, a signature motor management device of ABB low voltage switchgear business.**

**Main benefits of ABB MCC with M10x**

- **Unmatched safety for protection for personnel and plant**
- **Simplicity and high functionality**
- **Integrated communications**
- **Reliable solution proven by years of market experience**
- **Flexibility in a standardized solution**
- **Less spare starter module types**
- **Rapid fault detection and rectification**
- **Easy integrate and access to digital service**
- **Fully integrated into ABB Ability™ CMES condition monitoring solution**

---

# Contents

<b>01. M10x low voltage MCC</b>	04
<b>02. A world of experience</b>	05
<b>03. A simply smart motor control center</b>	06
<b>04. One size fits all</b>	08
<b>05. Unlocking ABB Ability™ digital services</b>	21
<b>06. Installation in MNS</b>	22
<b>07. Installation in NeoGear</b>	23
<b>08. Parameter assignment and programming</b>	24
<b>09. M10x product overview</b>	27

# 01. M10x low voltage MCC

A reliable, available, simple, safe and powerful motor control center solution

## Product portfolio

ABB low voltage switchgear replace traditional multiple protection devices with single standalone protection and control relays engineered directly into the switchgear modules. The standard but multi functional starters serve a broad range of motor management applications and bring the outstanding customer values for both EPCs and end users:

- Full-spectrum protection and control functions
- Flexible function change during design stage
- More condition data due to more measurement input
- Industry standard communications for seamless control system integration

## Simple, yet highly functional

M10x is a solid feature and functionality device that offers simple-to-advanced motor protection and control functions.

- Multiple motor control and protection functions
- Local control panel for control and monitoring
- Motor starter and load feeder (with motor MCCB) monitoring and control
- Additional I/Os for hardwired interlock and basic control functions

## Flexibility in a standardized solution

M10x low voltage motor control center solution is the intelligent solution based on the proven ABB MNS® platform and extended to the new generation ABB NeoGear™.

- Standardized solution with simplified schematics
- Single front, back-to-back or duplex (\* Duplex switchgear is not available in NeoGear.) switchgear arrangement
- Plug-in or withdrawable modules, even when combined in one vertical section
- Easy to modify existing switchgear by replacing modules

## ABB Ability™ CMES

M10x low voltage motor control center is the solid foundation of of ABB's condition monitoring for electrical systems Ability™ CMES and fully integrated into ABB Ability™ condition monitoring for electrical system.



## 02. A world of experience

More than a decade of market-proven consistent and reliable solution!



With years of exposure to the market, M10x has a large installed base in many industries. From mines deep underground to power plants, paper mills and factories on the surface, M10x has a global reputation for reliability and ease-of-use.

### **Mining and minerals**

- Easy operation, highly flexible process control and supervision
- Comprehensive motor protection, including earth fault
- Multiple configurable digital inputs/outputs for monitoring and control

### **Water industry**

- Pump control and protections
- Plant automation support, from starters to feeders
- Reliable network support with dual communication interfaces

### **COG**

- Complete monitoring and control of processes
- Built-in undervoltage monitoring and protection
- Advanced auto-restart function



## 03. A simply smart motor control center

M10x motor control center (MCC) is a microprocessor-based intelligent motor management system that provides users with complete and specialized low voltage motor control, protection and monitoring.

Its splendid, all-in-one functionality, robust communication and commercially economical qualities make M10x a trademark ABB intelligent motor controller. It has been chosen and delivered for many projects worldwide, especially in the regions where the most reliable and proven solutions are demanded. It is no surprise that M10x has become the number one choice of our customers and end users.

### Making the right decisions at the right time

M10x MCC is an intelligent system, based on ABB's low voltage platform. This system offers superior protection, control and monitoring that supports a fully user-optimized approach to motor management.

M10x collects all relevant information from the process involved, including timely alarms, enabling plant operators to make the right decisions based on precise, real-time process conditions.



Process control system,  
Energy management system,  
Emergency shut down system

Modbus TCP, Profibus or Modbus RTU

(\*Profinet via additional converter)

**Increasing plant availability**

M10x significantly increases plant availability by enabling preventive action. Its data quality goes far beyond conventional motor protection systems. With integration into ABB Ability™ Condition Monitoring CMES this can further be shifted to condition-based and predictive maintenance practices.

**Flawlessly integrated communications**

M10x provides typical low voltage energy distribution and motor control center communications vertically to process control systems, and horizontally across engineering and maintenance stations. Configurable in a simplex or dual-redundant manner, M10x is flexible to meet a wide range of customer requirements.

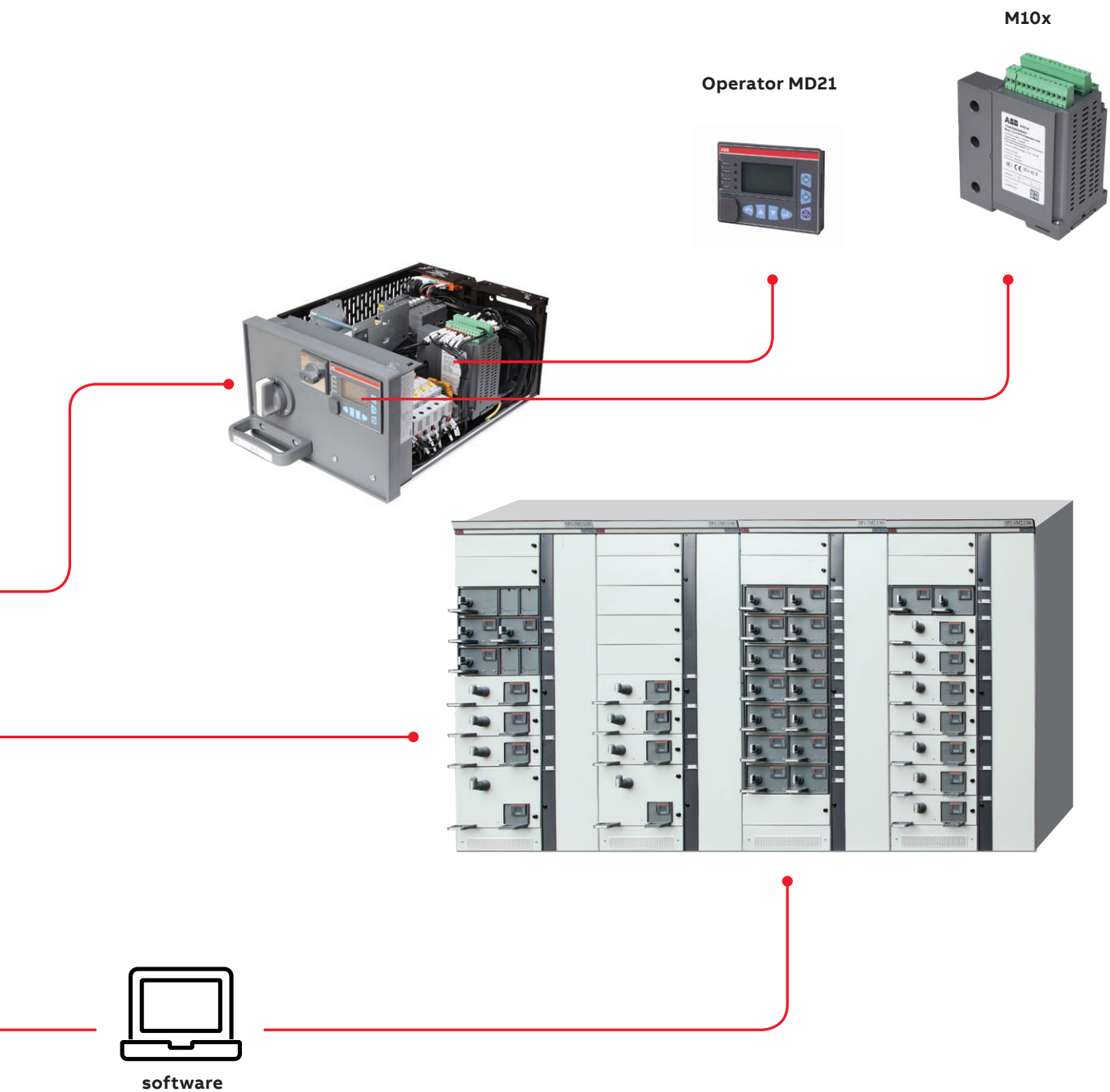

M10x

Operator MD21

software

## 04. One size fits all

### Simple engineering solution

A single, uniquely equipped device, M10x can be

customized through its software to perform all of the varied tasks customers require.

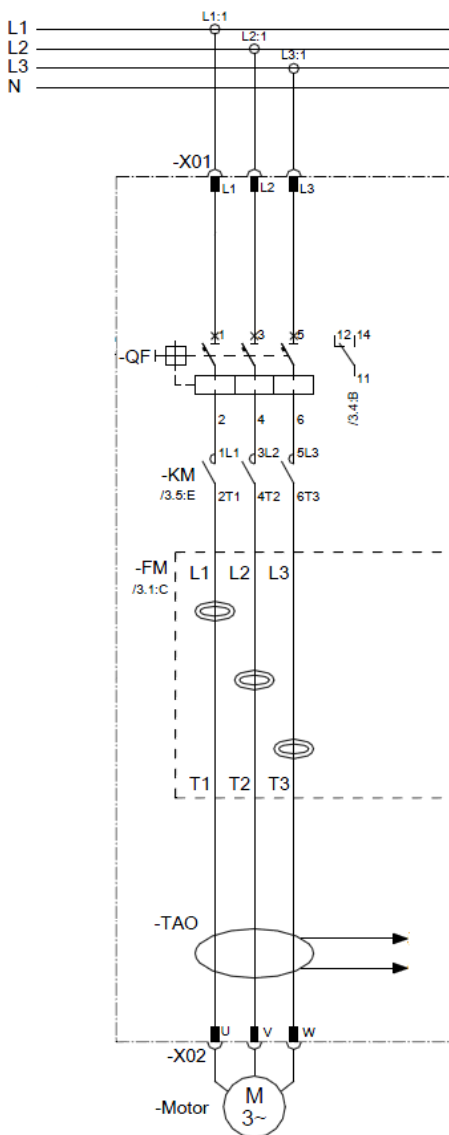

### Operator panel MDx

#### MD21 (LCD panel)

Control, monitor, parameterization



#### MD31

Control & indication



### One size product

- Control, protection, monitoring & communication in one device
- Multiple choice of power supply i.e., 24 V DC, 110AC & 240 V AC
- One type of integrated current transformer (CT) ranging from 0.24- 63A  
External CT is required from 63~6300A
- One physical dimension regardless of different M10x variants



### Residual Current transformer (RCT)

M10x dedicated RCT, i.e. LNG CT is required for earth fault current measurement from 100mA~15A



**Flexible and user friendly I/O design**

**Note:**  
Different product types may have different quantities of I/Os. Please refer to product user manual for details.

M10x supports up to 13 digital inputs and 5 digital outputs in one single device. All inputs and outputs are configurable to suit different applications.

M10x provides one set of analogue output with the extension AO module.

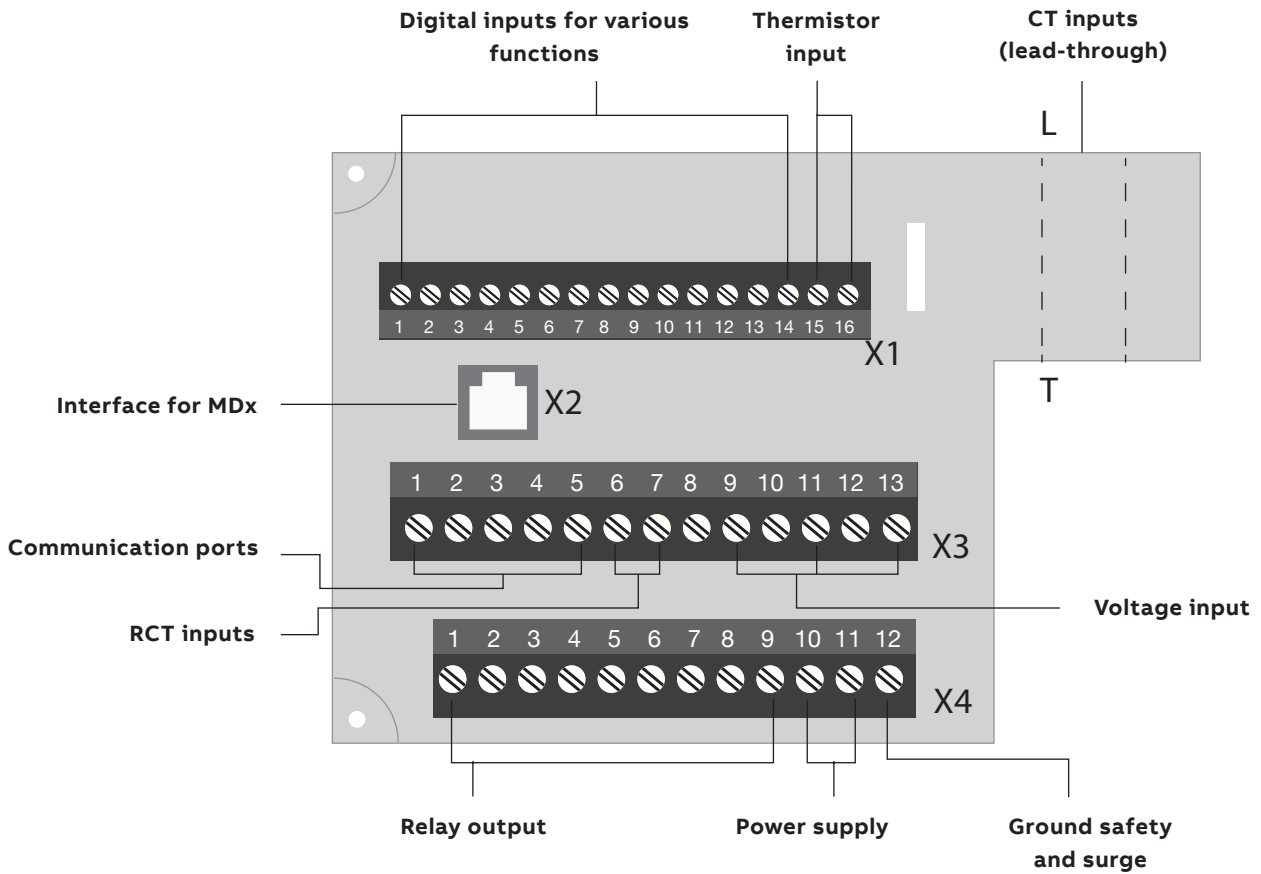

**Multiple starter types**

M10x relays provide a full range of functionalities for motor monitoring, control and protection.

M10x offers a variety of motor start modes via parameterization, and supervises the operating state of the contactor through the feedback of the auxiliary contact of the contactor. The control authority of the motor includes local control and remote control.

All necessary motor starting control modes are integrated in the device. To select a desired starting control mode, simply click on the setup interface of the M10x motor control unit.

**Remarks:****RCU**

RCU is an option to control the contactor by bypassing the M10x.

**Actuator**

Starter type is based on reversing direct on line starters where limit switch inputs are used to stop the motor in some necessary cases like valves, dampers, actuators etc.

**Feeder**

Feeder mode is listed as a specific start mode in M10x to serve for circuit controlling and supervising for motor operated MCCB feeder.



**Table 1 Starter type**

Start modes	M101	M102
Non-reversing direct online NR-DOL	▪	▪
NR-DOL with remote control unit (RCU)	▪	▪
Reversing direct online REV-DOL	▪	▪
REV-DOL with RCU function	▪	▪
Actuator (e.g., valve or damper control)		▪
Start / Delta starter		▪
Two speed starter with separate windings		▪
Autotransformer		▪
NR-Softstarter		▪
REV-Softstarter		▪
Feeder (motor operated)	▪	▪
Dahlander starter		▪
Contactor feeder	▪	▪
Contactor feeder with RCU function	▪	▪

### Motor Protection Functions

M10x devices provide timely and accurate motor protection by continuously collecting and keeping track of information on all operating states during the course of motor operations, providing fault alarm and protection action (protection trip) and setting action delay times, to safeguard motors and smooth production. Via serial communication, real-time information of process motors is reported upward to plant control systems, providing the basis for process analysis and management optimization. Prior to any possible major fault in the equipment, a limit-exceeding alarm will alert the operator in a timely manner to take corrective actions to prevent unnecessary shutdown. This provision maximizes the operating efficiency of the equipment.

When the preset alarm level is reached, the 'alarm' message is generated and reported. As soon as the preset trip level is crossed, a timer is activated and the count down to motor tripping starts. The time duration for count down is set according to the 'trip delay' parameter. The count down continues as long as the fault exists. The motor eventually trips out when the setting delay time runs out. If the fault is corrected before the countdown reaches 0, the timer is reset and switched off - no trip will follow. In any of the above cases, the event message is generated. In addition to this, operating data such as 'time to trip' and 'time to reset' can be collected and reported via communication network.

Alarm level, trip level and trip delay, illustrated

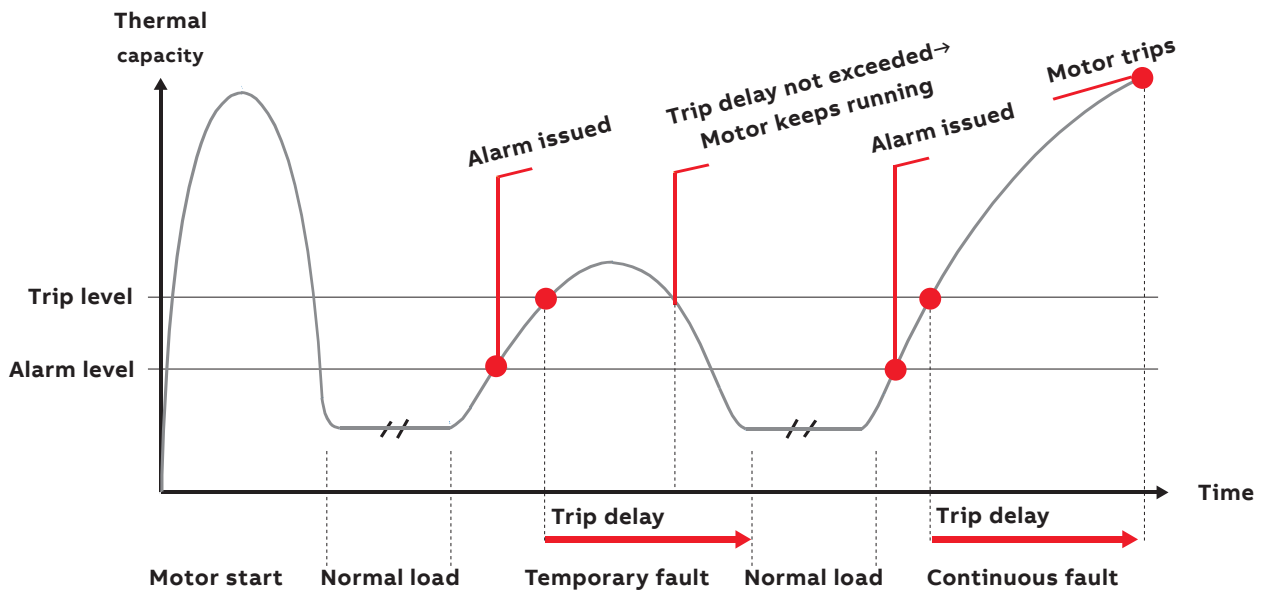

Alarm and trip data set according to motor manufacturer's specification and process needs.

**M10x motor protection has the following features:**

- All protection functions are available in a standard device and configurable for different applications
- The desired protection function can be easily selected with the parametering software
- The protection function can be set as alarm and trip, alarm only, or trip only
- Trip reset modes can be configured as any of the following by preset of trip reset modes

**The reset modes are different in various protection functions:**

- Automatic reset
- Remote reset
- Local reset
- Local & remote reset

**Table 2 Protection function**

Motor protection functions	ANSI	Description	M101	M102
TOL protection	49	Tracks and calculates the thermal capacity of the motor in operation to protect the motor against overheating.	▪	▪
TOL EEx e	49	The overload protection is designed for Exe, i.e. the increase safety type of motor which is used for explosive atmosphere.	▪	▪
Long start protection	50	Protects the motor against locked or stalled rotor in start state.	▪	▪
Start limitation protection	66	Limits the number of starts during a time interval. Number of starts and time interval are parameter settings.	▪	▪
Phase failure protection	46	Uses the minimum/maximum line current ratio as the criterion for enabling the phase failure protection function.	▪	▪
Phase unbalance protection	46	Unbalance can be caused by pitted contacts, faulty motor, loose connections, etc. The difference between the minimum and maximum phase currents is compared against the set parameters. Reverse phase protection not supported for the IEEE standard.	▪	▪
Stall protection	50	Protects against stall, the highest measured phase current to compare against the set parameters, activates only after motor start-up time is complete.	▪	▪
Undervoltage protection	27	Protects the motor against undervoltage condition (voltage drop or loss).	▪	▪
Autorestart		Auto restart the motor after voltage dips. Depending on the type of voltage dip and the duration of the dip, immediate restart and delayed restart may be triggered.	▪	▪
Under load/No load protection	37	Detects loss of load condition and disconnect the load in case any damage on the installations may be caused.	▪	▪
Earth fault protection	50G 51G	Protects the motor against the earth fault condition with an additional residual current transformer with adjustable trip level and time delay.	▪	▪
Motor temperature protection (PTC)	38	Protects against too high temperature by using PTC sensors. The resistance values are compared against the set levels.	▪	▪
Motor temperature protection using PTC relay	38	Monitors motor winding temperatures from PTC sensors against preset values using an additional thermistor relay.	▪	▪
Phase sequence protection	47	Protects motor against connection in wrong sequence.	▪	▪

### Thermal overload protection

Thermal overload (TOL) protection keeps track of and calculates the thermal capacity of the motor in operation to protect the motor against overheating, which may shorten the service life of the motor or damage it. In addition, the thermal memory function of the TOL protection is particularly important in case frequent starting is required.

The TOL protection has a thermal memory function, which protects the motor from startup in an overheated condition. The M10x unit simulates the thermal conditions in all operating states of the motor to maximize the use of the motor on the premises for safe operation. The TOL protection takes into consideration the temperature rise of the motor rotors and stators, as well as the impact of the three - phase unbalance on the overheated motor. When the 'restart' command is issued before the temperature drops to the pre-set restart level after a 'TOL Trip', the M10x device will then suppress the command and the motor will not be restarted.

### TOL protection

The trip level, alarm level and reset level can all be adjusted by setting the parameters or altering constant values.

### TOL EEx e protection

EEx e protection takes into consideration the stall/nominal current ratio and the maximum motor temperature allowed by the environment class definition. Relevant data of EEx e motor is provided by motor manufacturer to direct programming into the M10x device without additional calculation.

### Thermal overload protection, illustrated

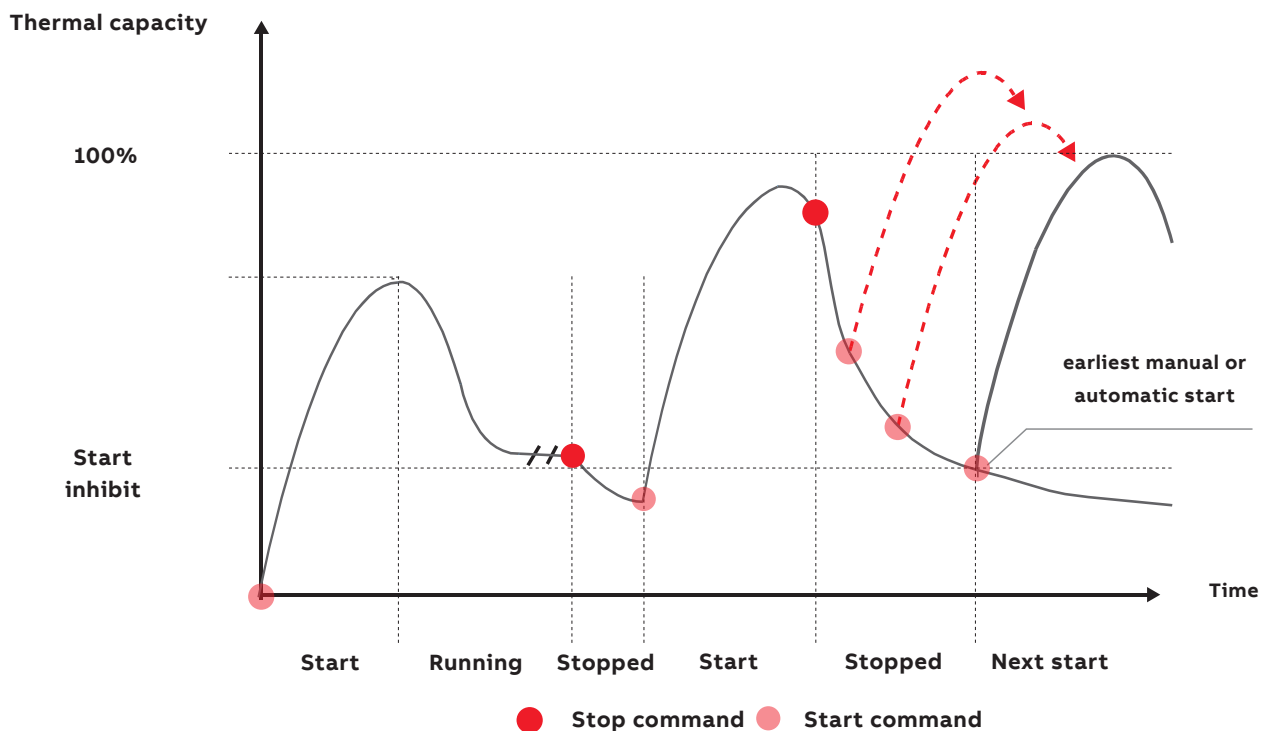

Thermal capacity must be below "Start inhibit" to allow a motor start.

### Earth fault protection

The earth fault protection function protects the motor against the earth fault condition with an additional residual current transformer. When the earth fault current exceeds the preset trip level, delayed trip or instantaneous trip is triggered. A toroidal current transformer is required for this function. Earth fault protection in M10x can be set to active or inactive during motor start up period.

ABB LNG CT is required for earth fault protection. ABB LNG CT is available in four different diameter dimensions:

$\phi 35$ ,  $\phi 70$ ,  $\phi 105$  and  $\phi 185$ .

- 1 A or 5 A current can be selected, depending on the setting range of the earth fault current of the protected system
- Shielded twisted pair should be used between outputs of LNG CT and terminals of M10x



—  
01 LNG CT

—  
Table 3 Technical data of LNG CT

Spec	Primary side input (A)	Secondary side output (V)	Secondary $\phi$ (mm)
LNG35 1 A	1	1	35
LNG35 5 A	5	1	35
LNG70 1 A	1	1	70
LNG70 5 A	5	1	70
LNG105 1 A	1	1	105
LNG105 5 A	5	1	105
LNG185 1 A	1	1	185
LNG185 5 A	5	1	185

**Undervoltage protection (M102 only)**

Undervoltage protection protect motor under voltage dips/loss. Related parameters are alarm level, trip level, trip delay and reset level.

**Undervoltage and autorestart (M102 only)**

After a sudden voltage dip (i.e. undervoltage trip level), M102 may restart the motor in 4 different ways depending on the type and duration of the dip(s). Related parameters are maximum auto reclose time, maximum power down time and stagger start delay time.

Case 1 - Voltage recovers within auto reclose time, the motor restarts immediately.

Case 2 - Voltage recovers between autoreclose time setting and the maximum power down time setting, motor restarts after a delay.

Case 3 - Voltage recovers after the maximum power down time, restart is prevented.

Case 4 - The case involves two voltage dips within 1 second. The duration of each voltage is less than 200ms. Under this case, motor restarts with a delayed time.

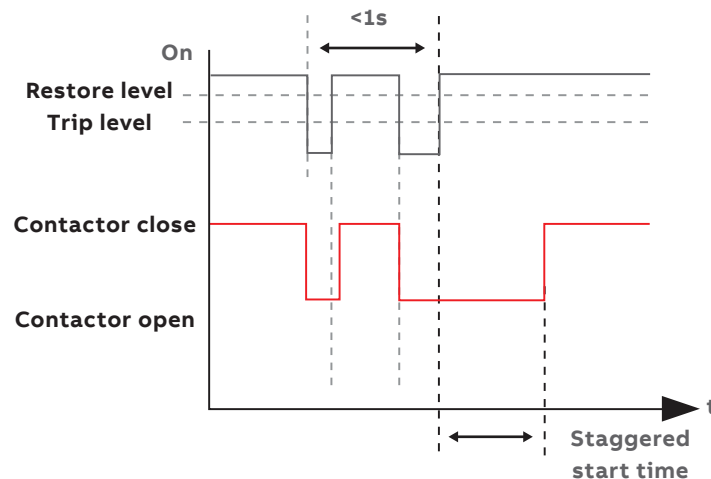

Autorestart case 4 (2x dips < 200ms)

### Extensive monitoring and reporting functions

M10x provides an extensive range of motor operation supervisory functions. Supervisory data are transmitted via the field bus to the upper level system for centralized management and are optionally directly displayed on the operator panel MD21 if installed on the front of the motor starter module.

**Table 4 Measurement and maintenance**

Monitoring and reporting		M101	M102	Description
Motor running data	Motor status	▪	▪	Start1, Start2, Stop, Alarm, Trip
	Three phase current	▪	▪	Relative value or actual value (only in MD21)
	Line voltage*		▪	Actual value of phase-phase voltage
	Power related*		▪	Include power, apparent power, power factor
	Thermal capacity	▪	▪	Thermal capacity of motor
	Frequency*		▪	Frequency of power system
	Energy*		▪	Energy consumed by motor
	Ground current	▪	▪	Ground current
	Thermistor (PTC)		▪	Value of PTC resistor
	Time to TOL trip	▪	▪	Time to trip triggered by TOL protection
	Time to TOL reset	▪	▪	Time to reset after TOL trip
	Digital input status	▪	▪	The status of each DI
	Startup time	▪	▪	Actual startup time of motor
	Current unbalance	▪	▪	Current unbalance between three phase current
Maintenance and service data	Sequence of events (SOE)*		▪	256 SOE with time stamp
	Running time	▪	▪	Running Time
	Stop time	▪	▪	Stop time
	Start number	▪	▪	Start number
	Stop number	▪	▪	Stop number
	Trip number	▪	▪	Trip number
	Last trip current	▪	▪	Three phase current of last trip
	Last EF trip current	▪	▪	EF current of last trip
	Module insertion cycles	▪	▪	Withdrawable modules insertion times
Parameter change number	▪	▪	Counter of parameter change	
Diagnosis data	Cause of alarm	▪	▪	TOL, overload, stall, phase failure, phase unbalance, underload, noload, earth fault, PTC*, under voltage*, autoreclose*, contactor feedback, welded contactor, PTC short circuit*, PTC open circuit*, start limitation, serial communication, running time, start number, watchdog, ready to trip reset, dix, insertion cycles, TOL bypass
	Cause of trip	▪	▪	TOL, stall rotor, phase failure, phase unbalance, underload, noload, earth fault, PTC*, under voltage*, contactor feedback, start limitation, serial communication, feeder trip, long start, emergency stop, external trip, dix, current feedback, main switch off, phase sequence

Note: 1) The parameters marked (\*) are only for M102.



**Operator panel**

M10x can optionally be equipped with an operator panel MDx1, which is used to display the status of the motor. Motor control is possible through predefined pushbuttons. A mini USB physical connection port is available on the operator panel for parameterization via service laptop and software.

The operator panel MD21 integrates the functions of measurement and maintenance display, LED indicators (configurable function) and has pushbuttons for operation and parameterization as well as fault monitoring functions.

MD21 and MD31 panels can be used for both M101 and M102 devices.

The basic type MD31 provides 4 LED indicators that are function configurable and has pushbuttons for operation.

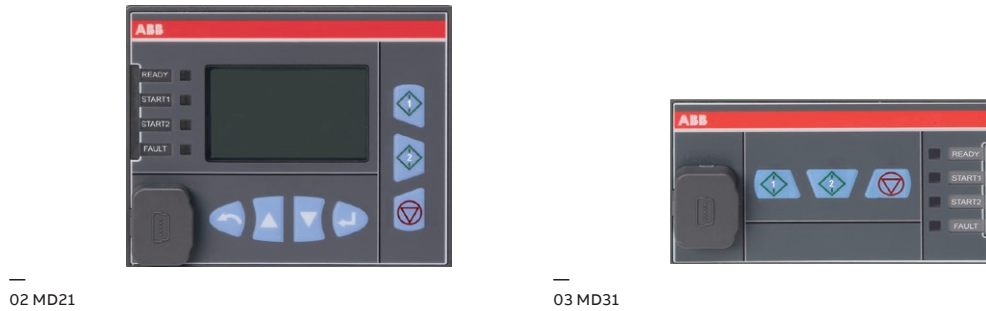
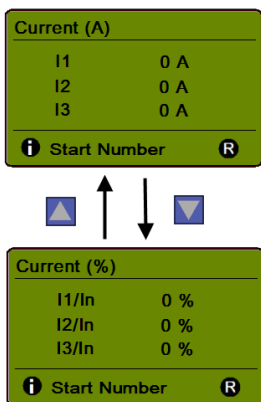

**Table 5 Operation panel**

Start modes	M21	M31	Description
Control buttons	▪	▪	Start1, Start2, Stop
Navigating buttons	▪		Page up, Page down, Enter, Exit buttons for navigating and parametering
LED indicators	▪	▪	Configurable function as Power, Ready, Start1, Start2, Running, Stop, Fault, Dlx
Parameterization interface	▪	▪	mini USB port
LCD window	▪		Motor running data *, Maintenance data *, Diagnosis information *, Product information, Setting parameters

\* Parameters including motor running data, maintenance data and diagnosis data which are listed on the table under ' Extensive monitoring and reporting functions' can be read on MD21 (change below drawing, refer to attachment)

**Monitoring value display page**



**Configurable!**  
13 pages in M102/  
8 pages in M101 at most

**Main configuration menu**

for any monitoring value display page →

← for any main configuration menu

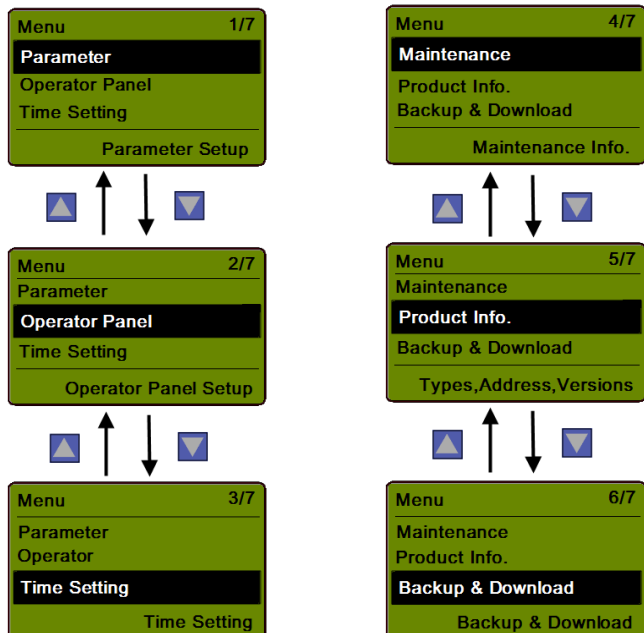

**Communication**

Direct communication available on M10x include,

- PROFIBUS DP V1 communications (up to 1.5 Mbps)
- Modbus RTU communication (Redundancy up to 57.6 kbps)
- Modbus TCP communication ( MRP supported)

Other communication including Profinet can be supported through a converter.

**Redundant communication**

M10x provides redundant connectivity provides higher availability in serial communication applications.

Modbus RTU, makes direct redundant serial communication possible. The M10x-M provides two identical RS-485 interfaces on the same device. Two Modbus RTU cables are connected throughout the switchgear assembly to each M10x-M. Both Modbus ports use the same communication parameters (address, speed, etc.).

For example, this allows the M10x-M to be connected to two communication lines to the upper-level process control system, or alternatively connect one line to the process control and the other to the management system.

With PROFIBUS DP, redundant communication to a process control system can be provided through a redundant link module RLM01. Inside the switchgear assembly, the PROFIBUS DP cable connection is single, while the connection to the upper-level process control system through the RLM01 module is provided as a redundant interface.

For MODBUS TCP, a ring topology is a daisy chain where the last controller in the chain loops back to the managed switch. The ring topology offers redundancy: if the network fails at any single point, the network segments on either side of the failure continue to operate as separate star or daisy chain topologies.

The MRP standard defines two principal device roles in a MRP network. The MRP manager which is typically a managed network switch, and MRP clients which are typically automation devices like the EM01. The MRP master sends out test telegrams cyclically to check the health status of the network. If everything is ok it blocks telegrams on one side of its internal switch to avoid loops (left side of the next figure). If somewhere in the network a fault is detected the MRP master reorganizes the network and closes its internal switch. So all network nodes are still accessible.

**M10x-M network (connected to Digital platform)**

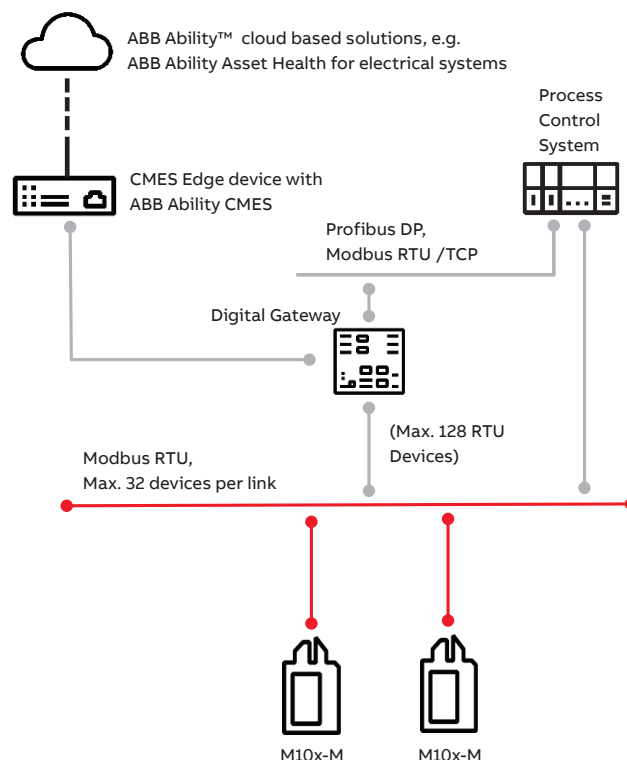

**M10x-M redundandct network (connected to Digital platform)**

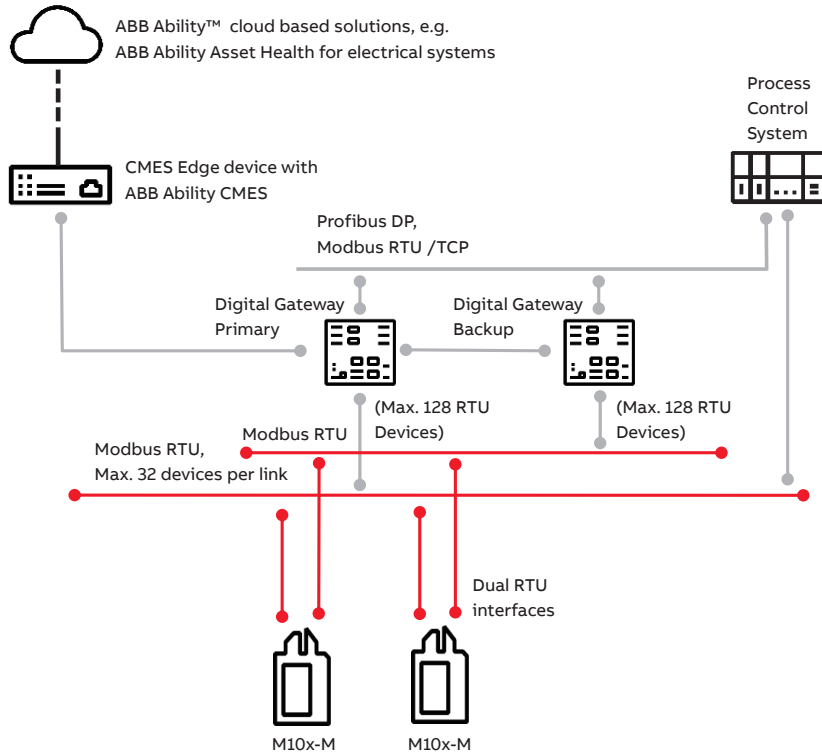

**M10x-TCP network (connected to Digital platform)**

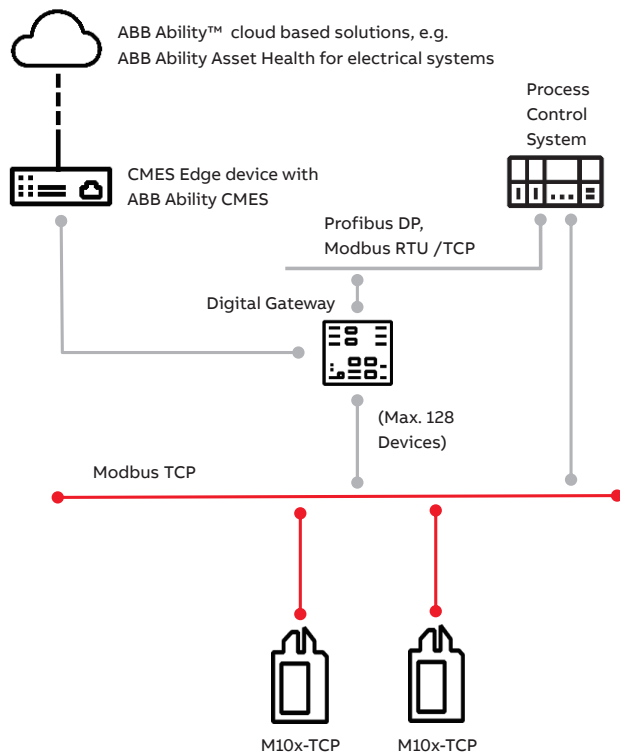

M10x-TCP Ring network (connected to Digital platform)

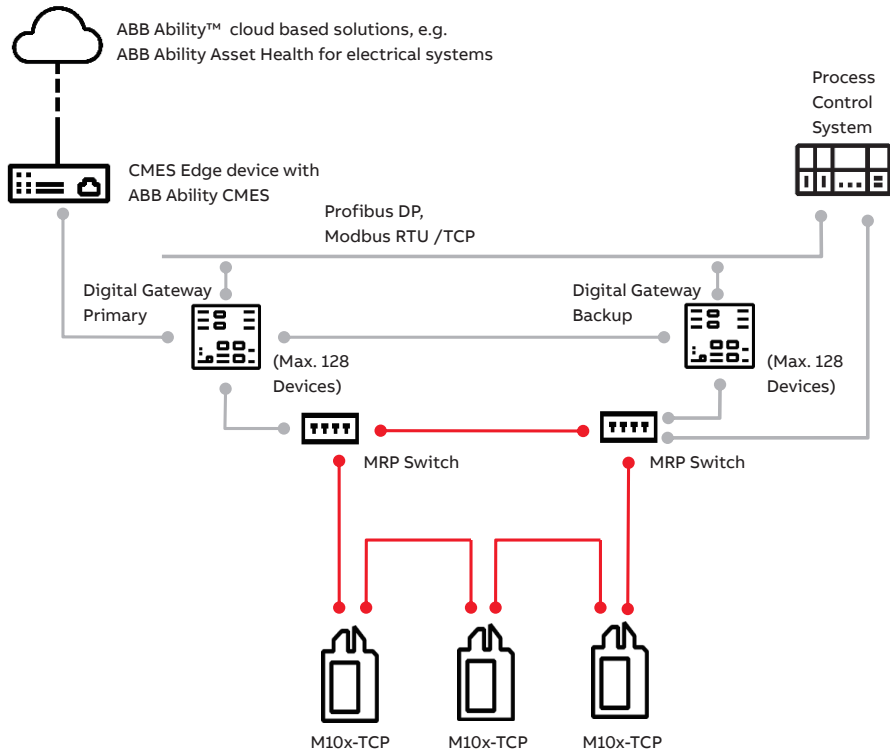

PROFIBUS network

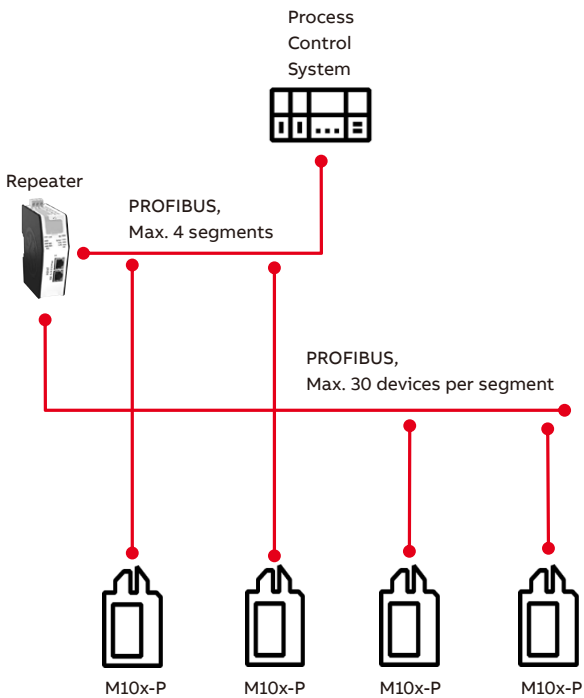

PROFIBUS Redundant network

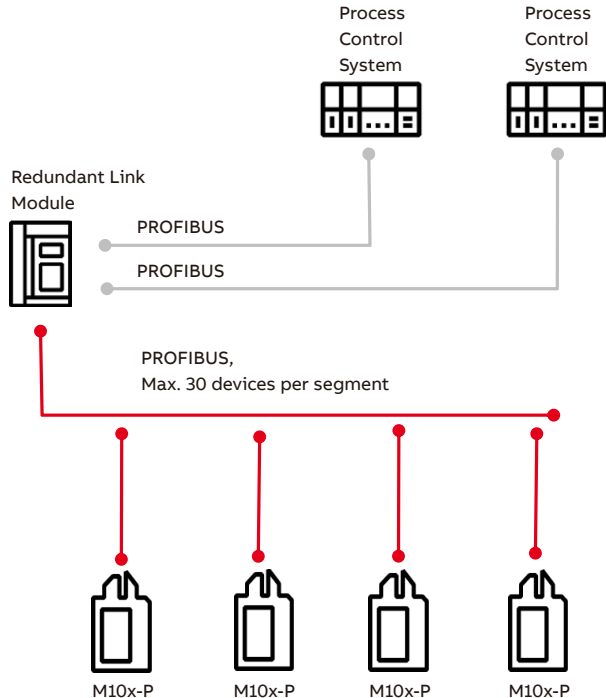

# 05. Unlocking ABB Ability™ digital services

M10x low voltage switchgear provides the hardware backbone to collect motor management and switchgear condition data and make them available.

It connects to the ABB Ability™ platform and makes data available on-premise through the ABB Ability™ CMES and further it makes the data available in the ABB Ability™ cloud solution. The ABB Ability™ dashboard provides you with real time data display, alarm and event display, trending and condition monitoring.

The connection to ABB Ability™ will make predictive maintenance a reality. It supports determining future conditions and gathering data from additional sources (including data beyond electrical values) so that condition becomes predictive.

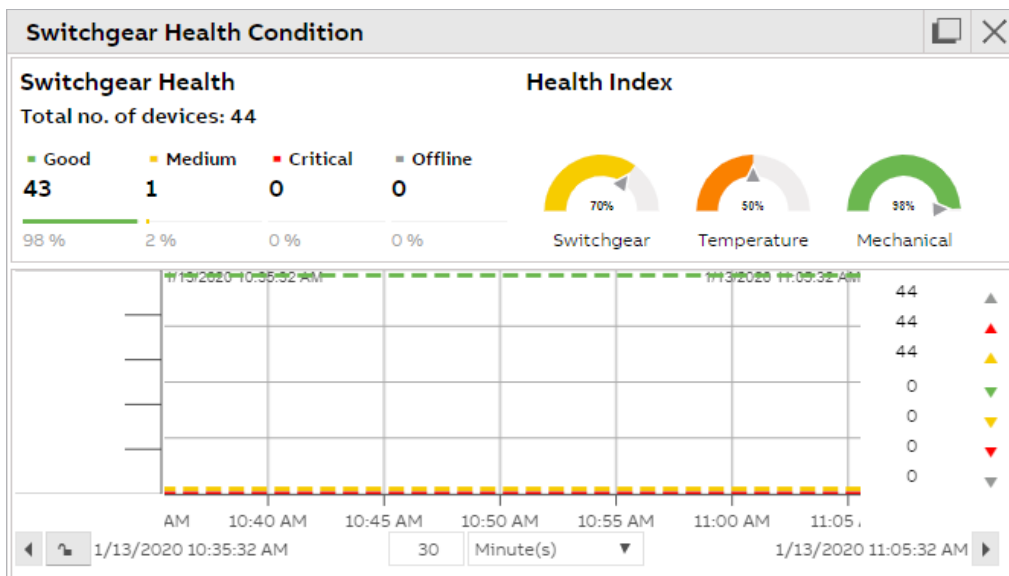
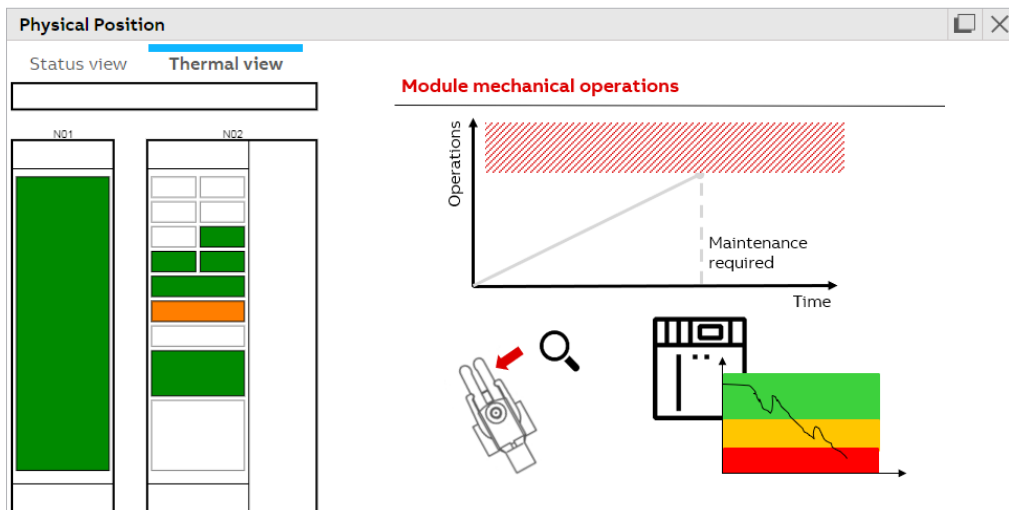

# 06. Installation in MNS

### M10x installation

M10x and the operator panel MDx are individually mounted and electrically connected to each other via the connection cable.

Compact size makes it possible to install M10x in the smallest size as the 8E/4 module of ABB's MNS switchboard.

The MDx operator panel is designed to be flush-mounted on the front or door of the MNS module. The following minimum mounting space requirements apply for MNS modules when used with the MDx operator panel:

Optionally a USB adaptor can be provided and installed on the module front when MDx panel is only required to be connected external of the starter occasionally.

Table 6 MNS M10x Module Configuration

Type	Withdrawable/Plug-in/Fixed
Typical Applications	DOL/REV
Typical Module sizes	8E/4 (*); 8E/2; 6E; 8E; 16E; 24E



04 8E/4 module



05 16E module

## 07. Installation in NeoGear

ABB NeoGear is a revolutionary low voltage switchgear, based on an innovative laminated busplate concept. Combined with the connectivity and digital smartness of the ABB Ability™ platform, it offers maximum safety, highest reliability, more flexibility, better efficiency and measurable ROI.

NeoGear module design is outstanding with sustainable space utilization. M10x is perfectly fit into this unique design and integrated seamlessly into ABB NeoGear platform.

Table 7 NeoGear M10x Modular configuration

Type	Withdrawable/Plug-in
Typical application	DOL/REV
Typical Module sizes	XS, S, M, L, XL

# 08. Parameter assignment and programming

The setup software for parameterization and configuration of M10x is user-friendly and MS Windows-based. Parameter setting is carried out via a dedicated parameter cable connecting the M10x to the MDx1 panel mounted on the front of the motor starter module. Software allows for the parameterization of all functions of the M10x types.

Simple setup windows make parameter setting easy to understand and follow. Import and export

setting functions offer a choice of managing setting files on or offline. For plants that require different access levels for security reasons, up to three levels of user groups can be defined as assigned under the user management menu.

### MCUSetup

MCUSetup can show the operation data and control via MD simulation tools, while the software collects service data from the motor.

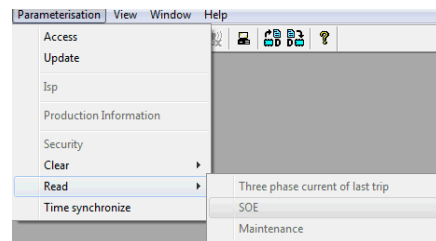
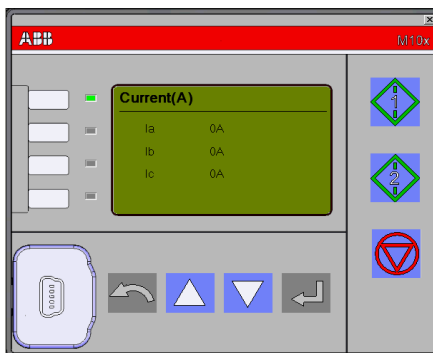
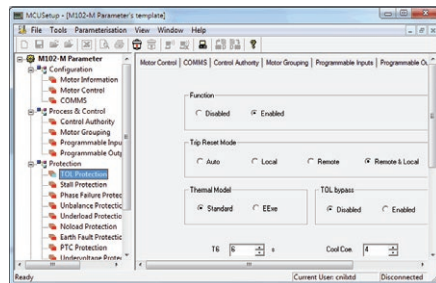
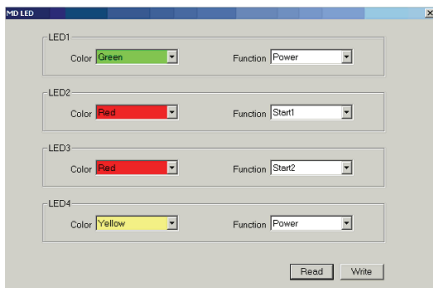



Alternatively, M10x can be equipped with an operator panel MDx for displaying the motor's operating, diagnostic and service data.

Predefined pushbuttons can control the motor. In addition, MCUSetup software provides diagnostics and operation.

**Table 8 Operating data**

<b>Motor status</b>
Current (A)
Current (%)
Line voltage*
Power related* (include power, apparent power, power factor)
Thermal capacity
Frequency
Energy*
Ground current
PTC resistor*
Time to TOL trip/reset
DI status
Startup time
Current unbalance

\*Available only in M102.

**Table 9 Alarm information**

<b>Alarm message- possible alarm causes:</b>		
TOL	Overload	Phase failure
Phase unbalance	Underload	No-load
Earth fault	PTC*	Undervoltage
Auto reclose*	Feedback	Welded contactor
PTC short circuit*	PTC open circuit*	Start limitation
Serial communication	Running time	Start number
Watchdog	Ready to trip reset	Dix
TOL bypass	Insertion cycles	

\*Available only in M102.

---

**Table 10 Trip information**

<b>Trip message - Possible trip causes:</b>		
TOL	Stalled rotor	Phase failure
Phase unbalance	Underload	Noload
Earth fault	PTC*	Undervoltage*
Contactors feedback	Serial communication failure	Start limitation
Feeder trip	Long start	Emergency stop
Dlx	External trip	Main switch status
Current feedback	Phase sequence	

\*Available only in M102.

\*\*"Trips" function is not only the indicator after a motor is tripped but also indicate that a motor is ready to trip before tripping or during motor stopped. e.g. an undervoltage or external trip (via DI) can activate the 'Trips' function while the motor is stopped.

---

**Table 11 Service data**

SOE*
Running time
Stop time
Start number
Stop number
Trip number
Last trip current
Last EF trip current
Insertion cycles
Parameter change number

\*Available only in M102.

## 09. M10x product overview



### Product type

Function options	M101-Simplified type, current based unit, limited range of protection functions
	M102-Advanced type, current and voltage based unit, full range of protection functions
Supply voltage options	24 V DC, 110 V AC, 240 V AC
Communication options	Modbus RTU, PROFIBUS DP, Modbus TCP

### Main unit M10x

#### Power circuit

Rated operation voltage (Ue)	up to 400/690 V AC 346/600 V AC(UL)
Rated insulation voltage (Ui)	690 V AC 600 V AC(UL)
Rated frequency	50/60 Hz
Motor current rating (Ie)	0.08-63 A (integrated CT)
	For 63 A above, external CT is required.

Starter coordination Refer to product coordination table

#### Control circuit

Rated operational voltage (Ue)	24 V DC, 110 or 240 V AC
Rated operational current (Ie) for contactor control relay output	2A/24 V DC (DC-13), 240 V AC (AC-15)
Trip rating	115% of TFLC

### Inputs and outputs

Digital inputs (configurable)	13 inputs (DC ) or 9 inputs (AC)
PTC input	1 channel PTC input (M102 only)
RCT (earth fault CT input)	1 channel RCT input
Digital outputs	5 outputs (M102) or 3 outputs (M101)

**Power supply**

Supply voltage	24 V DC, 110 or 240 V AC
Power consumption	4.5 W 24 V DC
	6VA 110 V AC
	12VA 240 V AC

**Accessories****Operator panel**

The operator panel is the user interface mounted on the module front or door, used for local monitoring, control and parameterization.

MD21	With LCD display, can be used to set up parameters through keypad
MD31	Without LCD display, can not be used to set up parameters via keypad

**Residual current CT**

ABB LNG, closed window type

Primary	1 A or 5 A
Window diameter	35 mm, 70 mm, 105 mm, 185 mm

**Analog Output module**

AO11 provides one channel 0-20 mA or 4-20 mA current loop output. The monitored parameters in M10x can be configured and converted to analogue signals through MCUSetup software.

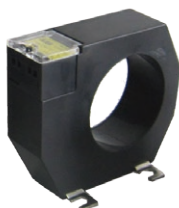
Power circuit	
Rated operational voltage (Ue)	24 V DC, 110~240 V AC
Voltage operation range	85%-110% Ue
Power consumption	1 W max
AO character	
Accuracy*	±0.5% of full range (20 mA)
Analog output	1 channel 4-20 mA/0-20 mA
Max load resistance	500 Ω

\* This accuracy is NOT include the measurement error of M10x.

**EM01**

Modbus TCP interface

Rated operation voltage (Ue)	24 V DC
Voltage operation range	85%-110% Ue
Power Consumption	
Typical	1.5 W
Maximum	2 W
Maximum starting current	100 mA
Protocol	Modbus TCP
Baud-rate	10/100 Mbps
Interface	RJ45

**Parameter setup software**

Parameter setup software for M10x is MCUSetup software. It is provided along with M10x product free of charge. MCUSetup software is running under windows environment including windows 10.

**Parametering cable set**

This is a special connection cable for parametering. It is with USB connector in one end to connect onto PC and mini USB connector on the other end for MDx connection. Converter is built in the cable.







—

**ABB Ltd.**

**Distribution Solutions**

Electrification business

P.O. Box 8131

CH-8050 Zurich, Switzerland

[new.abb.com/low-voltage/products/switchgear](http://new.abb.com/low-voltage/products/switchgear)

**Contact us through your local ABB contact center**

[new.abb.com/contact-centers](http://new.abb.com/contact-centers)

**Additional information**

We reserve the right to make technical changes or modify the contents of this document without prior notice. With regard to purchase orders, the agreed particulars shall prevail. ABB AG does not accept any responsibility whatsoever for potential errors or possible lack of information in this document.

The information in this document is subject to change without notice and should not be construed as a commitment by ABB. ABB assumes no responsibility for any errors that may appear in this document.

In no event shall ABB be liable for direct, indirect, special, incidental, or consequential damages of any nature or kind arising from the use of this document, nor shall ABB be liable for incidental or consequential damages arising from use of any software or hardware described in this document.

This document and parts thereof must not be reproduced or copied without ABB's written permission, and the contents thereof must not be imparted to a third party nor be used for any unauthorized purpose. The software described in this document is furnished under a license and may be used, copied, or disclosed only in accordance with the terms of such license.

All rights reserved.  
Copyright © 2020 ABB.