BROCHURE

System pro E power

Top Busbar System



—

System pro E power is the innovative ABB's main distribution switchboard solution with rated current up to 6300A and short-circuit current up to 120kA. Designed to easily fulfill all electrical installation requirements in terms of protection degree, segregation form and electrical characteristics, according to the latest international standards and in perfect synergy with all ABB's low voltage equipment.

Contents

002	Your key resource
004	Reliable in extreme condition
006	Space saving
007	Main distribution system
008	A patented technology
009	Certifications, type-approvals and laboratory tests
010	Composition of the series
012	Segregations in accordance with Standard IEC 61439-1-2

Your key resource

System pro E power, ABB's pioneering solution for main distribution switchboards with rated current up to 6300A and shortcircuit current up to 120kA, meets all plant requirements depending on the type of installation, required degree of protection and electrical and mechanical specifications.



Thanks to this switchboard, ABB can provide complete solutions for main electric power distribution in infrastructures and industries, in accordance with the regulatory framework.

Typical fields of application are airports, subways, hospitals, industrial and residential estates, tunnels, railways, theaters and so on.

A major plus of System pro E power is the full synergy with all other ABB apparatus (i.e. modular circuit-breakers, Tmax T and XT moulded-case circuit-breakers, Emax 2 air circuit-breakers...)

Great attention has been made to the wiring requirements, with adequately sized structures and pre-engineered sites for mounting the horizontal and vertical plastic ducts.



Reliable in extreme condition

Thanks to the tests performed on the product, the enclosures can stand a rated short-time withstand current (I_{cw}) up to 120kA and a Maximum rated current up to 6300A.

Anti-seismic certification

Anti-seismic is an important thematic which is properly implemented in ABB by testing product solutions that meet the growing security demands and requirements from different markets.

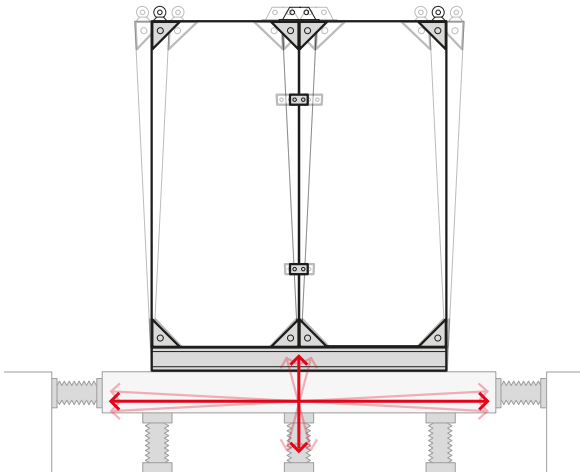

For System pro E power, ABB guarantees a seismic resistance in standard version without additional reinforcement elements up to 0.69g and with reinforcement kit up to 0.75g.

In order to meet the anti-seismic requirements, ABB offers a seismic qualification, in accordance with CEI EN 62271-207, which determine the total withstand capability of the switchgear assemblies in case of seismic stresses, combining results obtained by test, algebraically results and other service loads.

Arc fault resistance

The safety is also guaranteed by the blind tops arc fault resistant (composed by two flaps that, in case of internal arc fault, allow its outburst upward, protecting an operator that could be present in front of the switchboard).

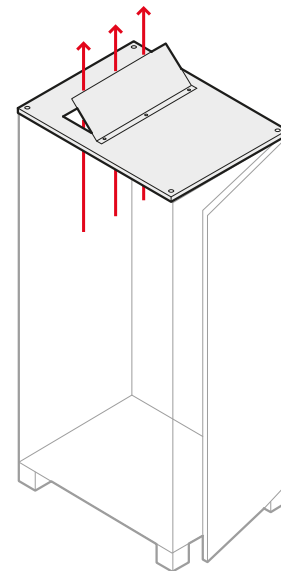



SAIPE Ener



MS

SAIPE Ener



ABB

ABB

ABB

ABB

Space saving

A wide variety of dimensions are available to meet all customer requests: 2 heights, 5 depths and 6 widths.

Furthermore, amperage from 2500A to 6300A can be reached in the minimum widths listed below:

- Up to 2500A (3P) installable in W=400mm
- Up to 4000A (3P) installable in W=600mm
- Up to 4000A (4P) installable in W=800mm
- Up to 6300A (4P) installable in W=1000/1250mm

For example, further space (up to 38%) can be saved by mounting two air circuit breakers in one column in 2500A, width 400mm (E2.2 F/W 3P), thanks to the dedicated components.



Main distribution system

System pro E power distribution system has been designed for improved flexibility and simple busbar connections.

Linear and scaled solutions are available and allow the busbars to be installed in any position: horizontally, under the top, on the bottom and at each height; vertically, along the side or at the rear and in the cable compartment. The structural components include:

- insulating support and tie rods
- crosspieces and brackets

The main advantages are:

- same construction philosophy for 250A to 6300A applications
- same multifunction insulating supports able to house flat busbars 5 and 10mm thick and shaped busbars ("click in" installation method for the linear version)
- the center distance between phases can be increased for the linear version by simply sliding the insulation support fastenings along the crosspieces

- same fixing crosspieces for both linear and scaled solutions
- stainless steel crosspieces for applications with $I_n \geq$ at 4000A to limit the effect of stray currents

The capacity of the busbars is as follows:

- flat copper busbars up to 6300A
- shaped profile busbars up to 2500A

Air and moulded-case circuit-breakers can be connected to the busbars by means of prefabricated rigid or flexible connections.

Number of busbars installable per insulator

	Linear System		Scaled System	
Flat busbars	1,2,3 or 4 bars per phase	50mm block 2000A	1,2,3 or 4 bars per phase	2000A
		75mm block 3200A		
		100mm block 6300A		
Shaped busbars	1 per phase	50mm block 1600A	1 per phase	1600A
		75mm block 2000A		
		75mm block 2500A		



A patented technology

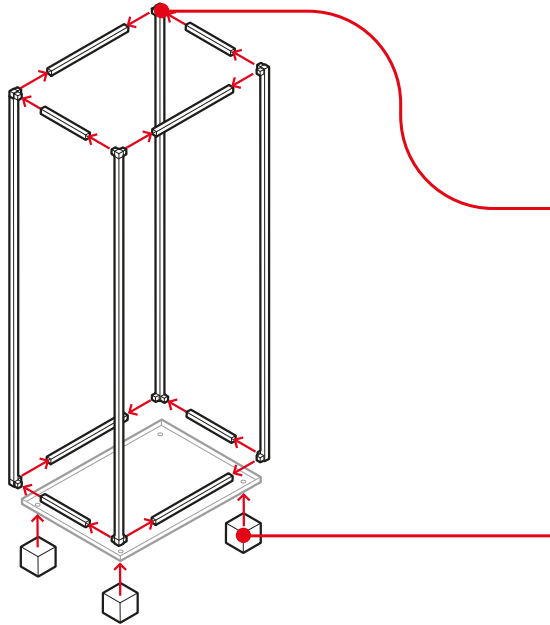

Patented joining system with 3 axial screws that makes the switchboard incredibly sturdy.

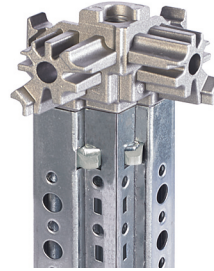

The plinth angle piece features a patented “folding” system that guarantees high-level mechanical strength and can be fastened from the inside and outside of the structure.

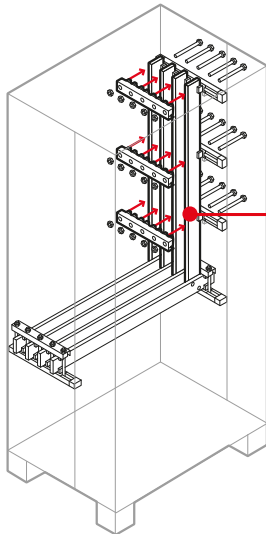

Patented Linear busbar insulated supports.

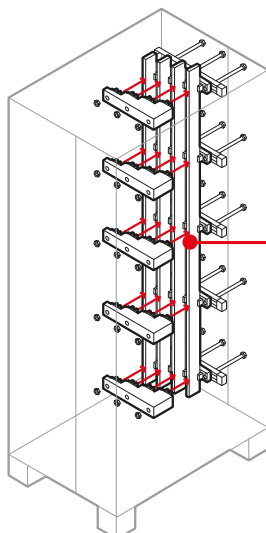
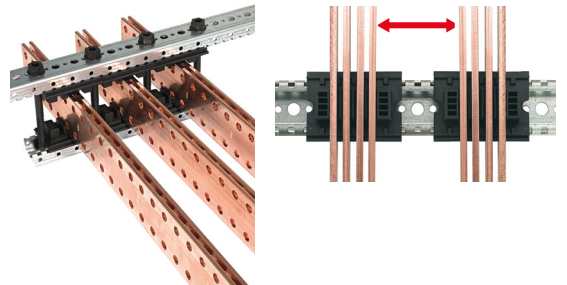

Patented scaled busbar insulated supports.

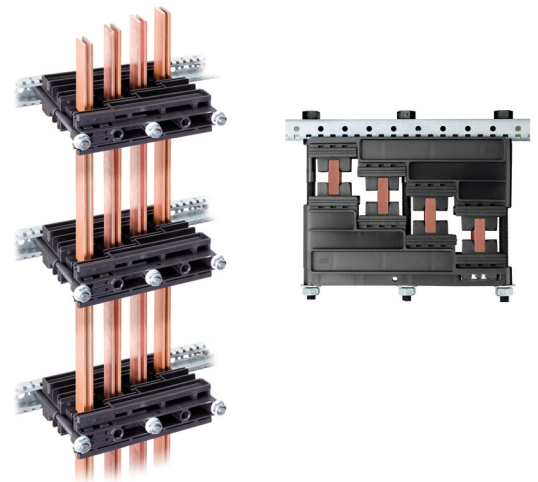

Certifications, type-approvals and laboratory tests

System pro E Power guarantees quality and safety in accordance with international standards IEC 61439-1 and 2.

Fully assessed and certified, the new System pro E Power switchboards have been subjected to all the type tests required by new standards IEC 61439-1-2 and IEC 60439-1-2. Certification was achieved after stringent tests that involved the entire configuration (structure, circuit-breakers and busbar system), thus systems conforming to the new international standards can be created by following ABB's instructions. System pro E power switchboard was subjected to electrical and mechanical tests at the ABB SACE Division's test laboratory, accredited in Italy by ACCREDIA and by important international certification bodies like ACAE/LOVAG, ANCE, ASTA, ETL SEMKO, UL, CSA and Shipping Registers.

Specifically:

- Temperature rise test
- Dielectric properties test
- Short-circuit withstand test

- Short-circuit strength of the protection circuit and shortcircuit withstand test
- Clearances and creepage test
- Mechanical operation test
- Protection class test
- Verification of thermal stability of enclosures
- Verification of resistance of insulating materials (Glow Wire test)
- Mechanical impact test
- Resistance to corrosion test
- Lifting and handling.

The test results guarantee tip-top performance, so the final switchboard constructor need not to conduct further type-tests or assessments if the components have been selected and assembled according to ABB's instructions. Individual verifications and testing the wired switchboard are left to the assembler.



Composition of the series

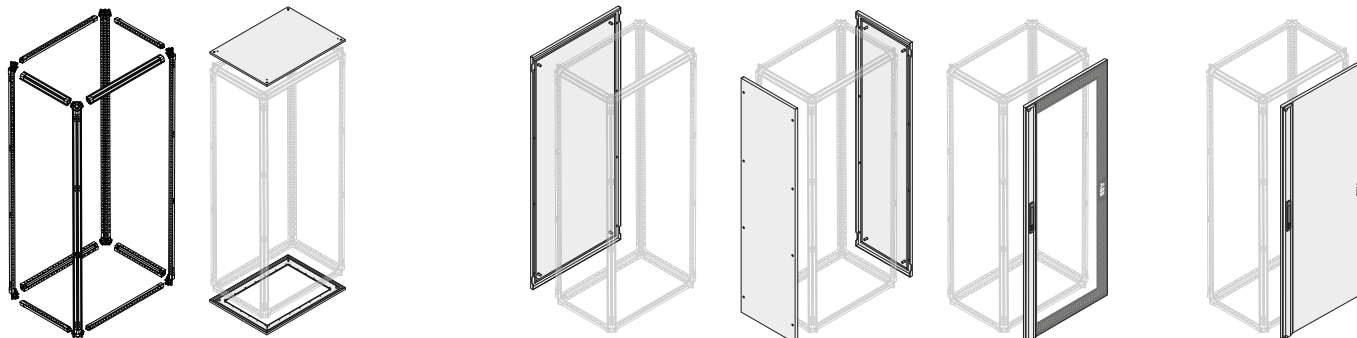

STRUCTURE			EXTERNAL COVERS										
Functional dimensions			Top/Bottom			Rear panel		Side panels		Door			
			Blind	Open ⁽¹⁾	Internal bottom	Blind	Vented	Blind	Vented	Glass	Blind		
H (mm)	W (mm)	D (mm)	IP30 to IP65	IP65	IP40	IP40 to IP65	IP30/31	IP40 to IP65	IP30/31	IP30 to IP41	IP65	IP30 to IP41	IP65
300		200	✓	✓	✓	✓	✓	✓				✓	✓
		300	✓	✓	✓	✓	✓	✓	✓			✓	✓
		500	✓	✓	✓	✓	✓	✓	✓			✓	✓
		700	✓	✓	✓	✓	✓	✓	✓			✓	✓
		900	✓	✓	✓	✓	✓	✓	✓	✓			✓
400		200	✓	✓	✓	✓	✓	✓		✓	✓	✓	✓
		300	✓	✓	✓	✓	✓	✓	✓	✓	✓	✓	✓
		500	✓	✓	✓	✓	✓	✓	✓	✓	✓	✓	✓
		700	✓	✓	✓	✓	✓	✓	✓	✓	✓	✓	✓
		900	✓	✓	✓	✓	✓	✓	✓	✓	✓	✓	✓
600		200	✓	✓	✓	✓	✓	✓		✓	✓	✓	✓
		300	✓	✓	✓	✓	✓	✓	✓	✓	✓	✓	✓
		500	✓	✓	✓	✓	✓	✓	✓	✓	✓	✓	✓
		700	✓	✓	✓	✓	✓	✓	✓	✓	✓	✓	✓
		900	✓	✓	✓	✓	✓	✓	✓	✓	✓	✓	✓
1800 2000		200	✓	✓	✓	✓	✓	✓		✓	✓	✓	✓
		300	✓	✓	✓	✓	✓	✓	✓	✓	✓	✓	✓
		500	✓	✓	✓	✓	✓	✓	✓	✓	✓	✓	✓
		700	✓	✓	✓	✓	✓	✓	✓	✓	✓	✓	✓
		900	✓	✓	✓	✓	✓	✓	✓	✓	✓	✓	✓
800		200	✓	✓	✓	✓	✓	✓		✓	✓	✓	✓
		300	✓	✓	✓	✓	✓	✓	✓	✓	✓	✓	✓
		500	✓	✓	✓	✓	✓	✓	✓	✓	✓	✓	✓
		700	✓	✓	✓	✓	✓	✓	✓	✓	✓	✓	✓
		900	✓	✓	✓	✓	✓	✓	✓	✓	✓	✓	✓
1000		200	✓	✓	✓	✓	✓	✓		✓	✓	✓	✓
		300	✓	✓	✓	✓	✓	✓	✓	✓	✓	✓	✓
		500	✓	✓	✓	✓	✓	✓	✓	✓	✓	✓	✓
		700	✓	✓	✓	✓	✓	✓	✓	✓	✓	✓	✓
		900	✓	✓	✓	✓	✓	✓	✓	✓	✓	✓	✓
1250		200				✓	✓	✓	✓	✓	✓	✓	✓
		900	✓	✓	✓	✓	✓	✓	✓	✓	✓	✓	✓

⁽¹⁾ Use the dedicated incoming cable flanges to obtain protection class IP65.

Segregations in accordance with Standard IEC 61439-1-2

Segregation form means the type of division inside the switchboard. Segregation by means of metal or insulating barriers or partitions may be required to:

- Provide protection against direct contacts (at least IPXXB) when a de-energized part of a switchboard must be accessed while the rest of it remains energized.
- Reduce the possibility of internal arc ignition and propagation.
- Prevent solid bodies from passing between different parts of the switchboard (protection class at least IP2X).

Partition means the element that separates two compartments while the barrier protects the operator from direct contact and from the effects of the arc of a switching device in the usual direction of access.

The partition can also be a casing that is an integral part of an apparatus, e.g. a moulded-case circuit-breaker.

Internal segregation kits

The different segregation Forms, (Form 2a, 2b, 3a and 4b), that can be created in the new System pro E power main distribution switchboard are described in the following pages. The descriptions include the following information for each segregation Form:

- the basic conditions for its creation
- the various solutions
- the reference tables for the choice of codes

Generally speaking, the basic segregation Form of the circuit-breaker kits (Form 1) passes to Form 4b by adding different accessories in sequence, depending on the case in question.

The main innovation introduced by the new System pro E power segregation system concerns the kits for circuit-breakers with front (with high terminals) and rear terminals for Form 2b.

Segregation Form 2a - 3a

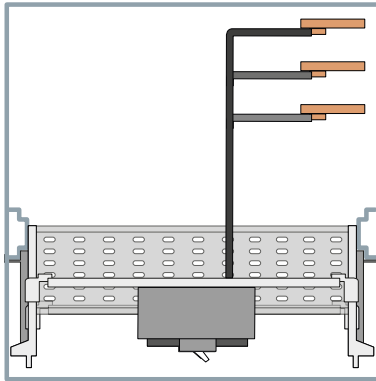

Segregation Form 2b - 4a

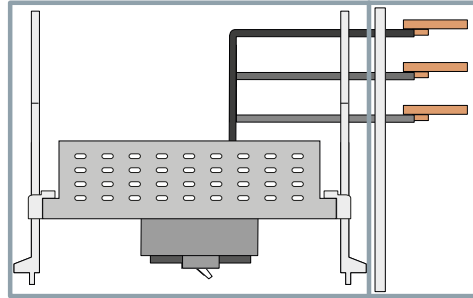

Segregation Form 3b

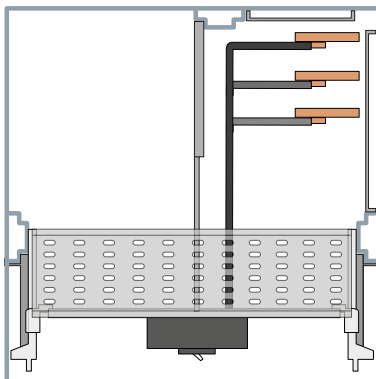

Segregation Form 4b

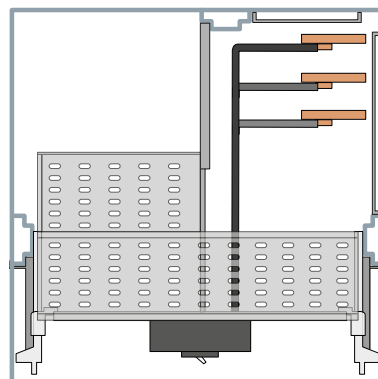



—
ABB S.p.A

Electrification Business - Smart Power

ABB SACE Division

58, Via Italia

I-23846 Garbagnate Monastero (LC)

Phone: +39 031 3570.111

Fax: +39 031 3570.228

www.abb.com

Due to possible developments of standards as well as of materials, the characteristics and dimensions specified in this document may only be considered binding after confirmation by ABB SACE.

© Copyright 2020 ABB. All rights reserved.